

Parameters and Function Blocks

The SIMOREG 6RA70 DC MASTER features an extensive parameter set that can easily be adapted to almost any drive task, from simple to complex. A wide scope of parameters include:

- Acceleration/Deceleration Control
- Automatic Restart Function
- Field Reversal
- Various Arithmetic and Boolean Logic Operations
- Technology Controllers
- Velocity/Speed and Diameter Calculators

In addition, the SIMOREG 6RA70 DC MASTER has extensive status indicators and display parameters for monitoring. The SIMOREG 6RA70 DC MASTER also supports a large database of faults and alarms. This provides the operator with a clear indication of what may be needed to correct the problem.

There are numerous parameters within the SIMOREG 6RA70 DC MASTER. It is beyond the scope of this course to cover these in any detail. However, it is important to understand how parameters and function blocks work together.

Parameters

Parameter values are used to provide settings to the drive. In the Siemens SIMOREG 6RA70 DC MASTER each parameter is clearly designated by an assigned number. Parameters are differentiated according to their function:

- Function Parameters (can be read and written)
- Visualization Parameters (can only be read)

Function Parameters

Acceleration or deceleration times are examples of function parameters. A feature of DC drives is the ability to increase or decrease the armature voltage gradually. This accelerates and decelerates the motor smoothly with less stress on the motor and connected load.

Parameters P303 and P304 work together to instruct the SIMOREG 6RA70 DC MASTER how much acceleration/ deceleration time is needed from 0 to 100% speed. P303 and P304 can be set to any value between 0.0 to 650 seconds. If P303 were set to 20.00, for example, the drive would take 20 seconds to accelerate the motor from 0 to 100% speed. Acceleration and deceleration time is linear which means the time speed curve can be accurately tracked. The motor would be at 25% speed after 5 seconds and 50% speed after 10 seconds.

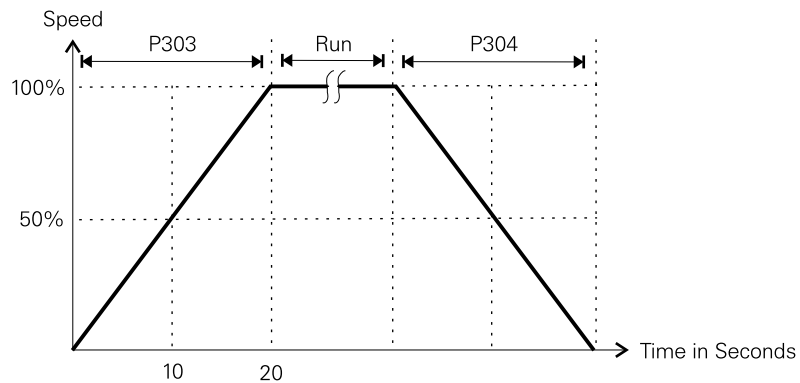

Rounding is a feature that can be added to the acceleration/ deceleration curve. This feature smooths the transition between starting and finishing a ramp.

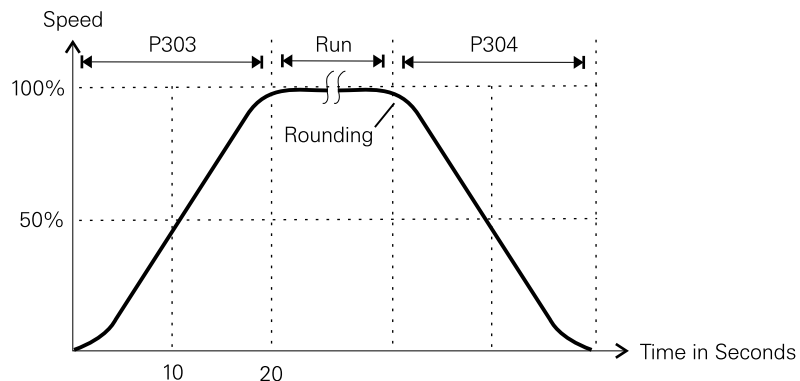

Visualization Parameters

Visualization parameters are used for visualizing internal quantities. These parameters are only displayed and cannot be changed by the operator. Visualization parameters are distinguished by a lower case "r". Parameter r038, for example, displays the value of voltage output to the motor.

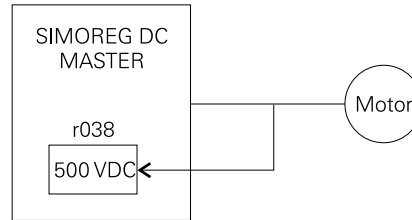

Function Blocks

A function block consists of several parameters grouped together to perform a specific task. The following function block represents one example of how a proportional/integral (PI) controller can be used in speed control of a SIMOREG 6RA70 DC MASTER.

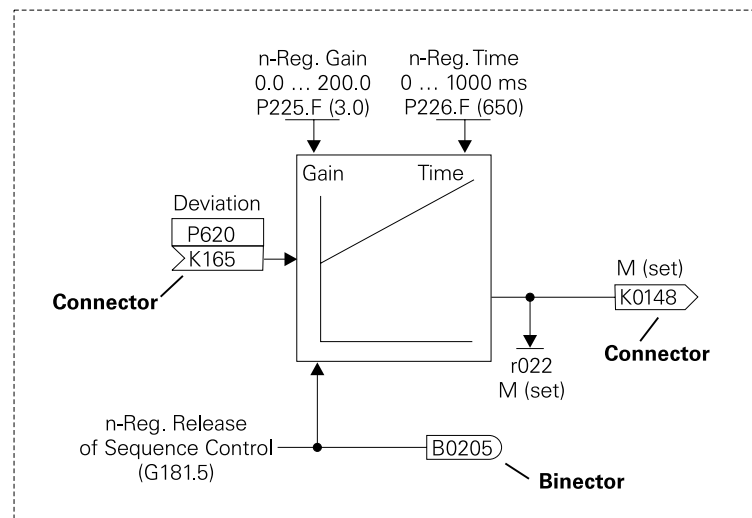

Function Parameters

The response of a function block is determined by function parameters. Proportional gain and integral time, for example, determine the response of a PI-controller. Each parameter has a name, identifying number, value range, and a factory setting. Function parameters can be indexed.

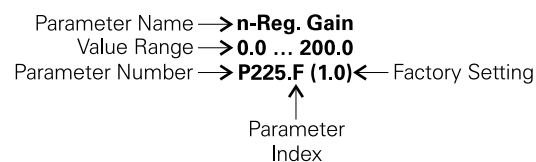

Indexing and Data Sets

In many applications it may be desirable to configure the SIMOREG 6RA70 DC MASTER for variations in operation. For example, there may be a situation in an application where it is desirable to have different acceleration times. Indexed parameters can have up to four different values stored with them. Each value stored is part of a data set. Parameter P303, acceleration time, is an example of an indexed parameter. P303 can have four different acceleration times stored. P303 could, for example, have the following values:

P303.1 = 0.50
P303.2 = 1.00
P303.3 = 3.00
P303.4 = 8.00

If data set 1 is active, the acceleration time is 0.50 seconds. If data set 2 is active, the acceleration time is 1.00 second. Data sets are operator selected and can be changed at any time.

PI-Controller

PI-controllers are commonly used in drive technology. In our example the desired speed and actual speed are input to a summation point. The two signals are opposite in polarity. When the actual speed is equal to the desired speed the deviation, which is input into the PI-controller, is zero (0). Whenever desired speed and actual speed are different there is a deviation.

Changes in load on the motor, for example, can affect motor speed. A sudden increase in load would cause the motor to slow down. This would decrease the feedback from actual speed and the deviation would become more positive. It is also possible that the application may require the motor to slow down or speed up. Until the motor reaches the new desired speed there will be a deviation.

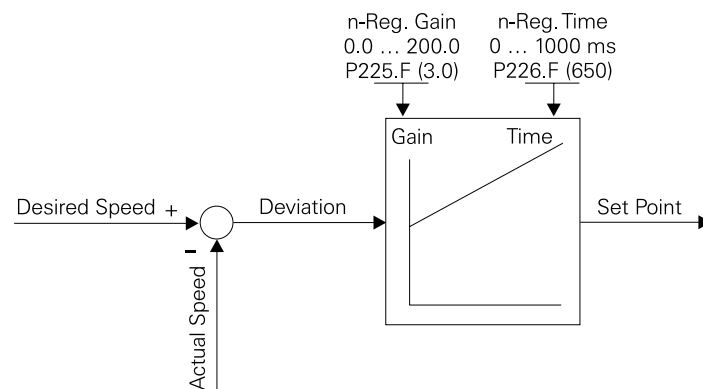

The PI-controller's job is to make speed corrections quickly a minimal amount of overshoot and oscillation. Parameter P225 (gain) and parameter P226 (time) are used to tune the PI-controller's performance. The end result should be a fast response time with about a 43% initial overshoot. The motor should then settle in to the new desired speed.

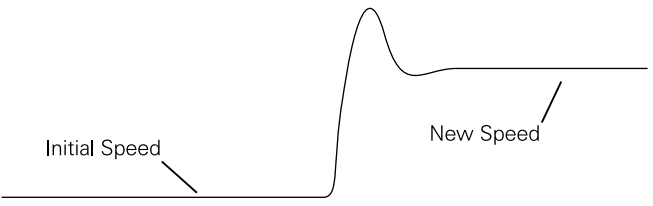

Connectors and Binectors

Connectors and binectors are elements used to exchange signals between function blocks. Connectors are used to store analog values. Analog values are stored in the form that is represented by 16 bit or 32 bit words. Binectors are used to store binary (digital) information.

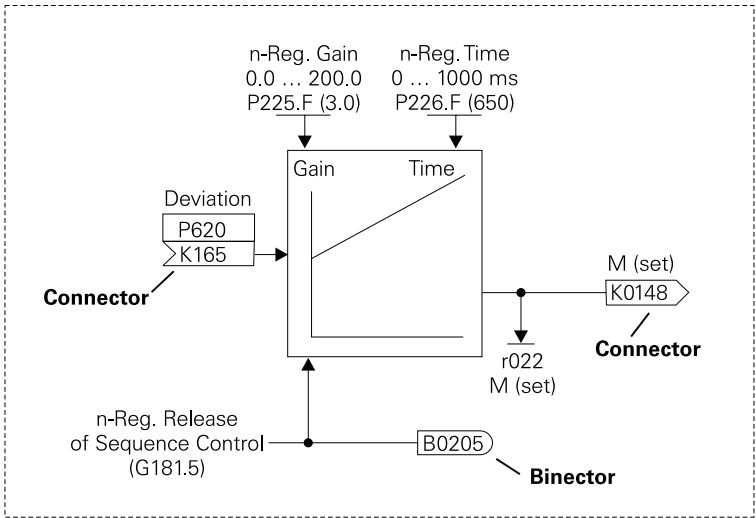

Connectors and binectors are identified by a name and number.
 Connectors with 16 bit resolution are identified with a "K."
 Connectors with 32 bit resolution are identified with a "KK."
 Binectors are identified with a "B."

Connector Name	M(set, n-Reg)
Connector Number (16 Bit)	K0148
Connector Name	Actual Position Value
Connector Number (32 Bit)	KK0046
Binector Name	Accel active
Binector Number	B0208

BICO

BICO is the term used to describe the method of connecting function blocks together. This is performed with **Binectors** and **Connectors**. A connection between two function blocks consists of a connector or binector and a BICO parameter. With BICO parameters you can determine the sources of the input signals of a function block. This allows the user to "softwire" function blocks to meet specific application requirements.

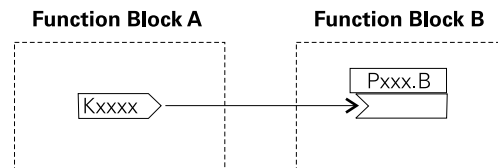

Engineering Tools

There are several engineering tools available optionally. These tools aid in programming, operating, troubleshooting, and managing SIMOREG 6RA70 DC MASTER drives.

SIMOVIS

SIMOVIS® can be used to aid start-up, setting and saving parameters, and as a diagnostic tool for troubleshooting. A feature of SIMOVIS is the graphics display. With this feature oscilloscope functions can be displayed on a computer screen.



QuickStart

QuickStart is another tool useful in setting up SIMOREG DC drives. A feature of this tool is the ability to communicate with specific drives in a network of drives. A Wizard driven menu leads operators through a simplified start-up procedure step-by-step.



Drive ES

Drive ES is used to integrate Siemens drives with the SIMATIC automation world. There are three Drive ES packages available.

Package	Description
Drive ES Basic	Structured similar to SIMOVIS allowing commissioning, parameter handling, oscilloscope readout, and fault evaluation. Based on STEP 7 for integration into SIMATIC.
Drive ES Graphic	Provides graphic configuring of BICO function blocks. Requires Drive ES Basic and a SIMATIC programming tool called SIMATIC CFC.
Drive ES SIMATIC	Provides function blocks and examples of SIMATIC projects. Requires Drive ES Basic.

Applications

When applying a DC drive and motor to an application it is necessary to know the horsepower, torque, and speed characteristics of the load. The following chart shows typical characteristics of various loads.

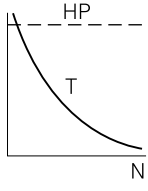
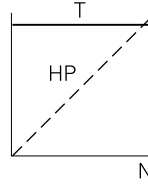
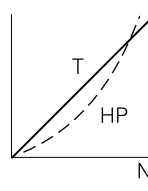
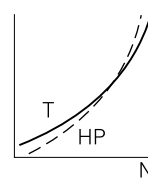
$T \approx \frac{1}{N}$	$T = \text{Constant}$	$T \approx N$	$T \approx N^2$
HP = Constant	HP \approx N	HP \approx N ²	HP \approx N ³
			
Winders Facing lathes Rotary cutting machines	Hoisting gear Belt conveyors Process machines involving forming Rolling mills Planers	Calenders with viscous friction Eddy-current brakes	Pumps Fans Centrifuges

Loads generally fall into one of three categories:

Category	Description
Constant Torque	The load is essentially the same throughout the speed range. Hoisting gear and belt conveyors are examples.
Variable Torque	The load increases as speed increases. Pumps and fans are examples.
Constant Horsepower	The load decreases as speed increases. Winders and rotary cutting machines are examples.

Application Examples

The Siemens SIMOREG 6RA70 DC MASTER drives are designed to handle the most challenging applications. The following examples are just some of applications the SIMOREG can be used on.

Winders/Coilers

DC motors offer superior characteristics at low speed for winder and coiler operation and performance. In winder applications maintaining tension at standstill is a very important operation. DC motors offer a wide speed range at rated torque. On many winder applications that run in an extended speed range a smaller horsepower DC motor could do the same job as a larger horsepower AC motor.

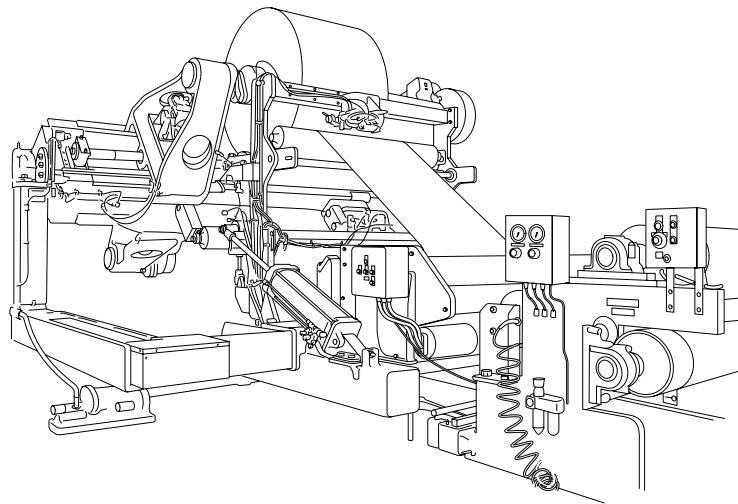

Marine Applications

DC drives offer several advantages in marine applications. Compact sizing is one of the biggest advantages. DC drives also adapt well from generator supplies such as found in the marine industry.

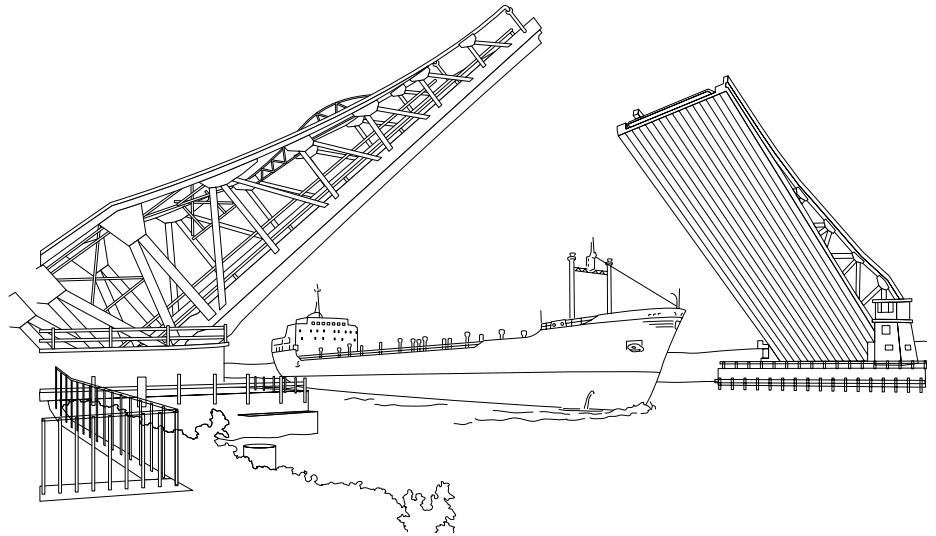

Crane/Hoist

DC offers several advantages in applications that operate at low speed, such as cranes and hoists. Advantages include low speed accuracy, short-time overload capability, size, torque proving control, and load sharing.

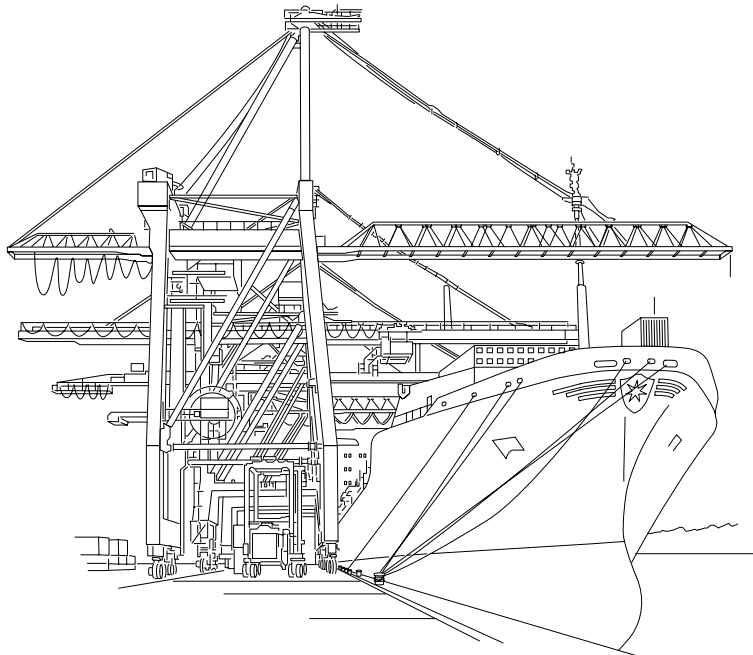

Mining/Drilling

DC is often preferred in the high horsepower applications required in the mining and drilling industry. DC drives offer advantages in size and cost. They are rugged, dependable, and proven in the industry.

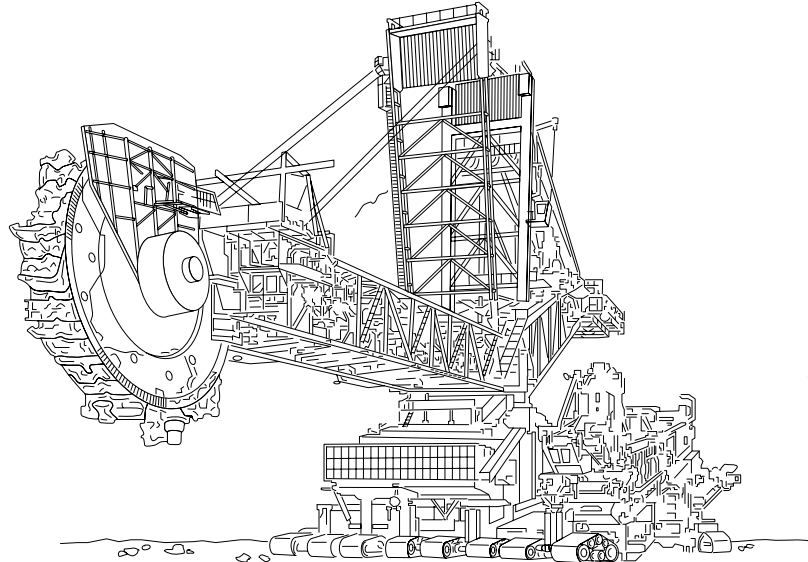

Extruding

Extruding is a price competitive industry. DC offers economical solutions in the 60 to 1000 HP range which is commonly used in extruding applications.

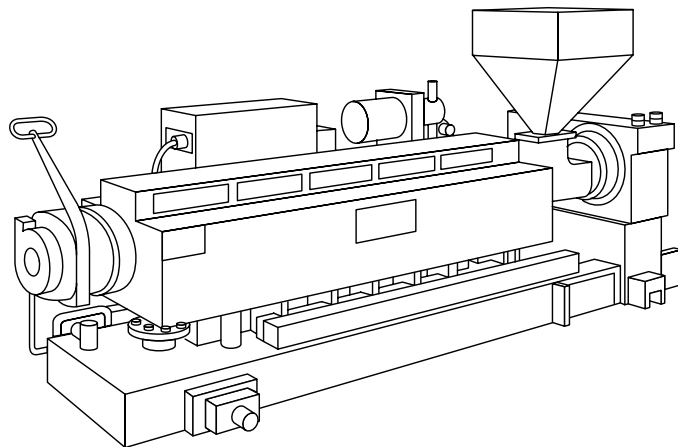

Selecting a Siemens DC Drive

The following flow diagram, along with the selection charts, will help you select the right DC drive for your application.

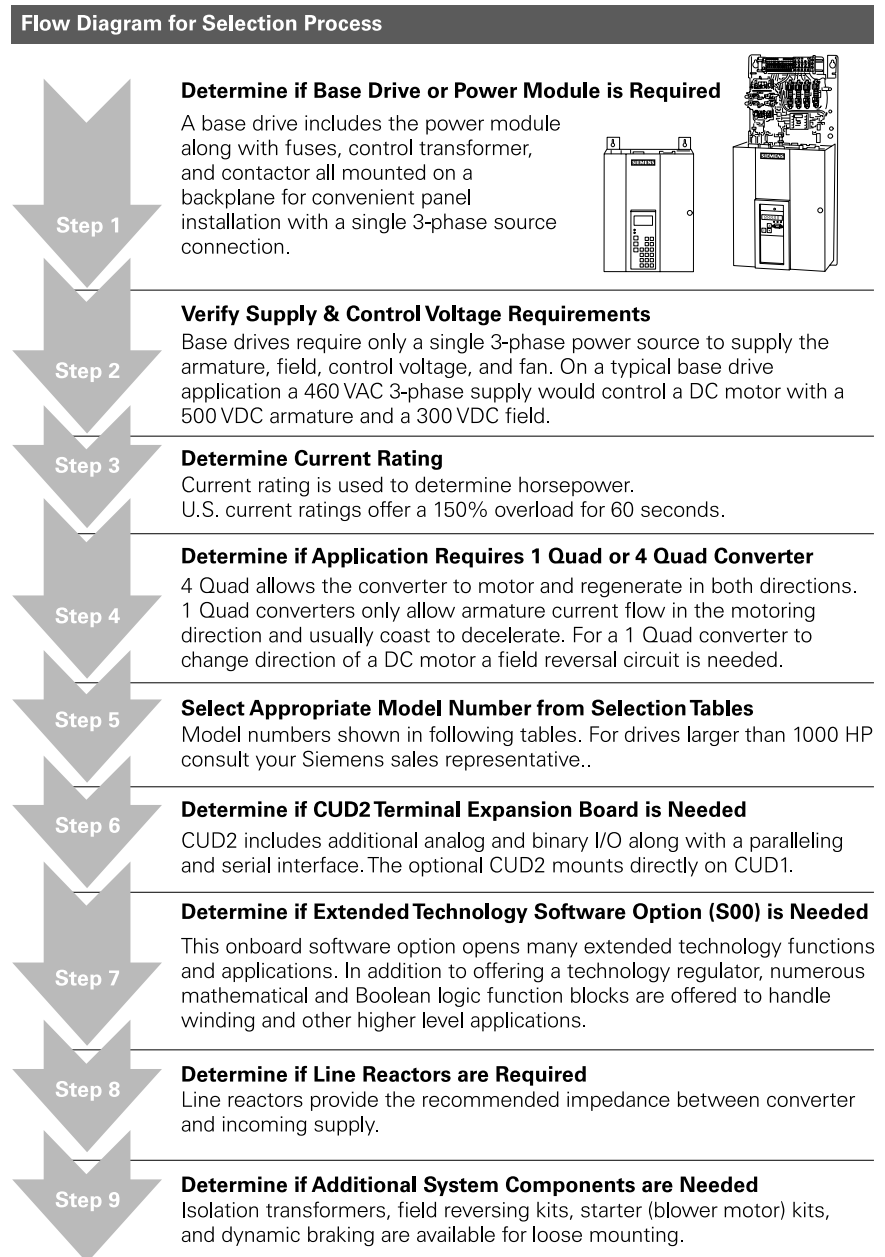

Flow Diagram for Selection Process

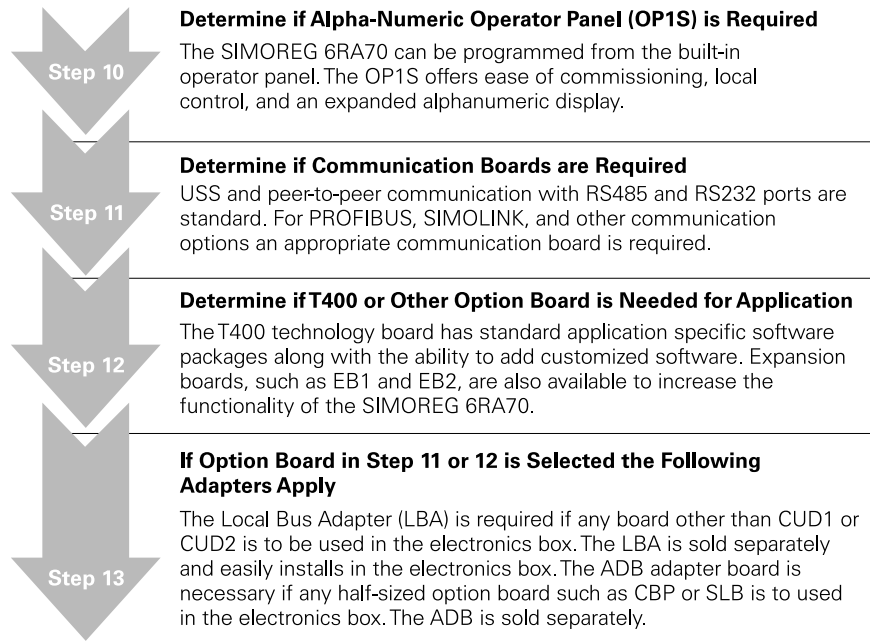

The following tables provide catalog numbers for SIMOREG DC drives up to 1000 HP. For larger drives consult your Siemens sales representative.

Power Module Single Quad, Non-Regen

Horsepower		Rated Armature (Amps DC)	Catalog Number
240 VDC	500 VDC		
3	7.5	15	6RA7018-6FS22-0Z+X01
7.5	15	30	6RA7025-6FS22-0Z+X01
15	30	60	6RA7028-6FS22-0Z+X01
25	60	100	6RA7031-6FS22-0Z+X01
40	75	140	6RA7075-6FS22-0Z+X01
60	125	210	6RA7078-6FS22-0Z+X01
75	150	255	6RA7082-6FS22-0Z+X01
125	250	430	6RA7085-6FS22-0Z+X01
150	300	510	6RA7087-6FS22-0Z+X01
250	500	850	6RA7091-6FS22-0Z+X01
-	700	1180	6RA7093-4GS22-0Z+X01
-	1000	1660	6RA7095-4GS22-0Z+X01

**Power Module
Four Quad, Regen**

Horsepower		Rated Armature (Amps DC)	Catalog Number
240 VDC	500 VDC		
3	7.5	15	6RA7018-6FV62-0Z+X01
7.5	15	30	6RA7025-6FV62-0Z+X01
15	30	60	6RA7028-6FV62-0Z+X01
25	60	100	6RA7031-6FV62-0Z+X01
40	75	140	6RA7075-6FV62-0Z+X01
60	125	210	6RA7078-6FV62-0Z+X01
75	150	255	6RA7082-6FV62-0Z+X01
125	250	430	6RA7085-6FV62-0Z+X01
150	300	510	6RA7087-6FV62-0Z+X01
250	500	850	6RA7091-6FV62-0Z+X01
-	700	1180	6RA7093-4GV62-0Z+X01
-	1000	1660	6RA7095-4GV62-0Z+X01

**Base Drive
Signle Quad, Non-Regen**

Horsepower		Rated Armature (Amps DC)	Catalog Number
240 VDC	500 VDC		
3	7.5	15	6RA7013-2FS22-0
7.5	15	30	6RA7018-2FS22-0
15	30	60	6RA7025-2FS22-0
25	60	100	6RA7030-2FS22-0
40	75	140	6RA7072-2FS22-0
60	125	210	6RA7075-2FS22-0
75	150	255	6RA7077-2FS22-0
125	250	430	6RA7082-2FS22-0
150	300	510	6RA7083-2FS22-0
250	500	850	6RA7087-2FS22-0
-	700	1180	6RA7091-2FS22-0
-	1000	1660	6RA7094-2FS22-0

**Base Drive
Four Quad, Regen**

Horsepower		Rated Armature (Amps DC)	Catalog Number
240 VDC	500 VDC		
3	7.5	15	6RA7013-2FV62-0
7.5	15	30	6RA7018-2FV62-0
15	30	60	6RA7025-2FV62-0
25	60	100	6RA7030-2FV62-0
40	75	140	6RA7072-2FV62-0
60	125	210	6RA7075-2FV62-0
75	150	255	6RA7077-2FV62-0
125	250	430	6RA7082-2FV62-0
150	300	510	6RA7083-2FV62-0
250	500	850	6RA7087-2FV62-0
-	700	1180	6RA7091-2FV62-0
-	1000	1660	6RA7094-2FV62-0

Review 7

1. Parameters that can be read only are referred to as _____ parameters.
2. A function block consists of several _____ grouped together to perform a specific task.
3. _____ is the term used to describe the method of connecting function blocks together.
4. Winders are examples of _____ applications.
5. Identify the category of the following speed, torque, and horsepower graphs.

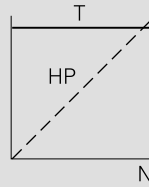

a. _____

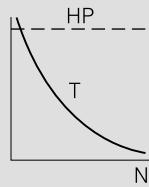

b. _____

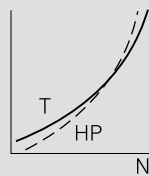

c. _____

Review Answers

- Review 1** 1) SIMOREG; 2) 15; 3) 15; 4) b. Dividing Distance by Time; 5) force; 6) external force.
- Review 2** 1) electromagnet; 2) current; 3) CEMF; 4) a. Permanent Magnet, b. Compound, c. Shunt, d. Series.
- Review 3** 1) a. increase; 2) c. not turning; 3) shunt; 4) b. torque; 5) flux.
- Review 4** 1) a. increase; 2) 250 VDC or 500 VDC; 3) a. A, b. B, c. F, d. H; 4) base; 5) b. AC to DC; 6) 538.
- Review 5** 1) I; 2) II; 3) shunt; 4) Dynamic Braking; 5) d. all of the above.
- Review 6** 1) CUD1; 2) Local Bus Adapter; 3) 2; 4) Armature; 5) 2; 6) CUD1; 7) b. EB1; 8) CBP2; 9) SLB; 10) SBP.
- Review 7** 1) visualization; 2) parameters; 3) BICO; 4) constant horsepower; 5) a. Constant Torque, Constant Horsepower, Variable Torque.

Final Exam

The final exam is intended to be a learning tool. The book may be used during the exam. A tear-out answer sheet is provided. After completing the test, mail the answer sheet in for grading. A grade of 70% or better is passing. Upon successful completion of the test a certificate will be issued. Those receiving a score of less than 70% will be provided a second test.

Questions

1. The type of DC motor best suited for use with DC drives is the _____ wound motor.
 - a. series
 - b. shunt
 - c. compound
 - d. series or shunt

2. _____ is the trade name for Siemens DC drives.
 - a. SIMOREG
 - b. SIMOVERT
 - c. SIMOVIS
 - d. SIMOLINK

3. The base speed of a motor is an indication of how fast the motor will turn with rated _____ and rated load (amps) at rated flux (Φ).
 - a. armature voltage
 - b. CEMF
 - c. field current (I_f)
 - d. armature resistance (R_a)

4. A decrease in field flux strength (Φ) causes a/an _____.
 - a. decrease in armature voltage
 - b. increase in armature voltage
 - c. increase in motor torque
 - d. decrease in motor torque

5. _____ is the voltage induced into an armature conductor of a DC motor in opposition to applied voltage.
- a. Armature voltage
 - b. Field voltage
 - c. CEMF
 - d. EMF
6. _____ current refers to the minimum amount of current flowing from anode to cathode to keep a thyristor turned on.
- a. Armature current
 - d. Gating current
 - c. Holding current
 - d. Field current
7. The value of rectified DC voltage obtained from a 460 VAC 3Ø source when the thyristors are gated at 60° is _____ VDC.
- a. 0
 - b. 310.5
 - c. 538
 - d. 621
8. A 1-quadrant drive uses _____ thyristors to convert AC to a variable voltage DC.
- a. 4
 - b. 6
 - c. 8
 - d. 12
9. _____ is a method sometimes used on 1-quadrant drives as a means of stopping a motor quickly by converting mechanical energy to heat.
- a. Regen
 - b. Field reversal
 - c. Dynamic Braking
 - d. Armature reversal

10. Which of the following is not an advantage of regen over dynamic braking?
- a. Regen brakes faster from max speed to base speed
 - b. Regen brakes faster from base speed to stop
 - c. Regen is not limited to duty cycle and cool-down periods
 - d. Regen can develop torque at zero speed
11. _____ tuning tunes the 6RA70 drive to the motor characteristics.
- a. Speed
 - b. Armature
 - c. CEMF
 - d. Field
12. _____ is the main control board in the 6RA70 which controls drive operation.
- a. CUD1
 - b. CUD2
 - c. SLB
 - d. CBP2
13. CUD2 requires _____ to install in the 6RA70.
- a. ADB Adapter Board
 - b. LBA Local Bus Adapter
 - c. ADB and LBA
 - d. No additional hardware
14. If a communication board (CBP2, CBC, or CBD) is used with a technology board, the communication board must be placed in slot _____.
- a. D
 - b. E
 - c. F
 - d. G
15. The command to start the 6RA70 drive is received on _____ of CUD1.
- a. Terminal 106 of XS
 - b. Terminal 4 of X174
 - c. Terminal 37 of X171
 - d. Terminal 14 of X175

16. Hoisting gear is an example of a _____ load.
- a. constant torque
 - b. variable torque
 - c. constant horsepower
 - d. constant speed
17. _____ is used to communicate with PROFIBUS-DP.
- a. CBC
 - b. CBP2
 - c. CBD
 - d. SBP
18. _____ is the term used to describe the method of connecting function blocks together.
- a. SIMATIC
 - b. SIMOVIS
 - c. BICO
 - d. QuickStart
19. _____ is an example of a visualization parameter.
- a. P225
 - b. r038
 - c. K165
 - d. B0205
20. The correct catalog number for a SIMOREG 6RA70 DC MASTER, base drive, four quad, to be used with armature amps rated for 100 amps is _____ .
- a. 6RA7031-6FS22-0Z+X01
 - b. 6RA7031-6FV62-0Z+X01
 - c. 6RA7030-2FS22-0
 - d. 6RA7030-2FV62-0

Notes

Notes

Notes